

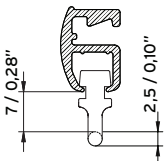









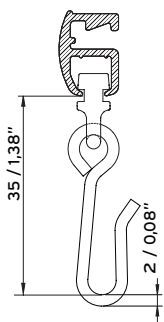

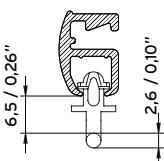

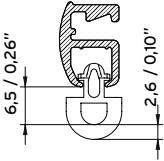

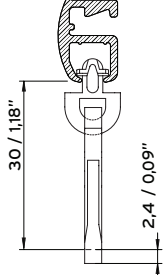

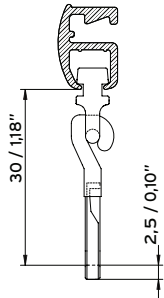

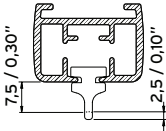

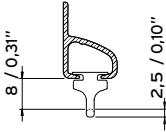
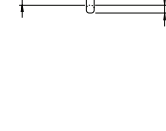
GLIDER SPECIFICATION SMALL CHANNEL

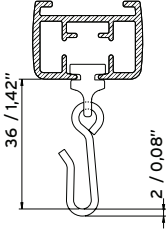
			width	max. load	for use with	colours
2010			10 mm 0,39"	1 kg 2,2 lbs	all small channel profiles	white, gold, brown
2011			10 mm 0,39"	1 kg 2,2 lbs	all small channel profiles	white, gold, brown
2012-10			10 mm 0,39"	0,5 kg 1,1 lbs	all small channel profiles (except 2400)	white
2012-40			10 mm 0,39"	0,5 kg 1,1 lbs	all small channel profiles (except 2400)	white
2012-50			10 mm 0,39"	0,5 kg 1,1 lbs	all small channel profiles (except 2400)	white
2025			10 mm 0,39"	1 kg 2,2 lbs	all small channel profiles	white

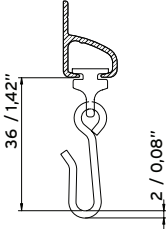
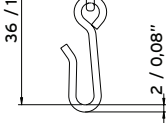

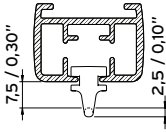
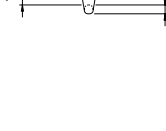

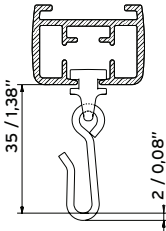
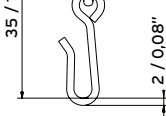



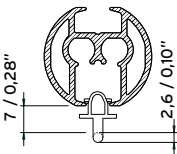

GLIDER SPECIFICATION WIDE CHANNEL

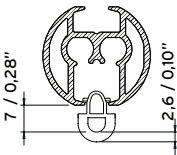
G-RAIL®

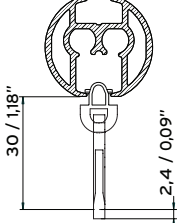
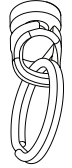
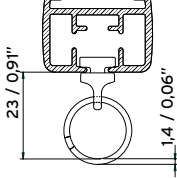

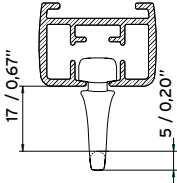

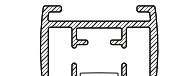

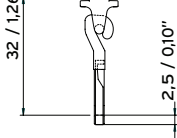
			width	max. load	for use with	colours
4007			10 mm 0,39"	2 kg 4,4 lbs	all wide channel profiles (except 4900)	white, silver
4007-LRS-10-GR			10 mm 0,39"	0,5 kg* 1,1 pound 8 kg/17,6 lbs release load	all wide channel profiles	grey
4007-LRS-20-R			10 mm 0,39"	0,5 kg* 1,1 lbs 12 kg/26,4 lbs release load	all wide channel profiles	red
4008			10 mm 0,39"	2 kg 4,4 lbs	all wide channel profiles (except 4900)	white, silver
4008-LRS-10-GR			10 mm 0,39"	0,5 kg* 1,1 pound 8 kg/17,6 lbs release load	all wide channel profiles	grey
4008-LRS-20-R			10 mm 0,39"	0,5 kg* 1,1 lbs 12 kg/26,4 lbs release load	all wide channel profiles	red
4010-10 (running out)			10 mm 0,39"	1 kg 2,2 lbs	all wide channel profiles (except 4900)	white, brown, gold
4010-11			10 mm 0,39"	3 kg 3,3 lbs	all wide channel profiles (except 4900)	white, brown, gold black
4011-10 (running out)			10 mm 0,39"	1 kg 2,2 lbs	all wide channel profiles (except 4900)	white
4011-11			10 mm 0,39"	3 kg 6,6 lbs	all wide channel profiles (except 4900)	white

08/2008 > drawing dimensions are given in mm/inches.
 > in case of bends: check the channel width after bending.
 > *loads mentioned may vary due to ageing of the material, humidity or varying temperature.

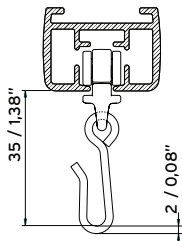
GLIDER SPECIFICATION WIDE CHANNEL

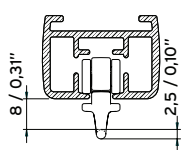
			width	max. load	for use with	colours
4012-10			10 mm 0,39"	0,5 kg 1,1 lbs	all wide channel profiles (except 4900)	white
4012-40			10 mm 0,39"	0,5 kg 1,1 lbs	all wide channel profiles (except 4900)	white
4012-50			10 mm 0,39"	0,5 kg 1,1 lbs	all wide channel profiles (except 4900)	white
4013-20			10 mm 0,39"	2 kg 2,2 lbs	all wide channel profiles (except 4900)	white, black, silver
4020			20 mm 0,79"	8 kg 17,6 lbs	4100, 4200, 4520, 4530, 4540, 4550, 4560, 4800, 5100, 5300, 5600, 6200 (also 6300 & 6302)	white, black
4025-10 (running out)			10 mm 0,39"	1 kg 2,2 lbs	all wide channel profiles (except 4900)	white, brown
4025-11			10 mm 0,39"	1 kg 2,2 lbs	all wide channel profiles (except 4900)	white, brown

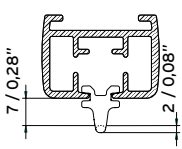
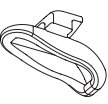
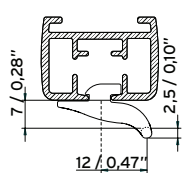
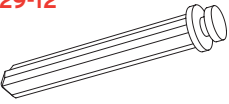
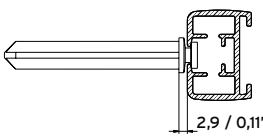
GLIDER SPECIFICATION WIDE CHANNEL

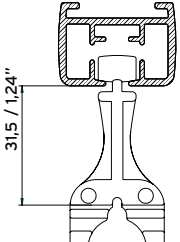
		width	max. load	for use with	colours	
4029			10 mm 0,39"	1,5 kg 3,3 lbs	4100, 4200, 4520, 4530, 4540, 4550, 4800, 5100, 5600, 6200 (also 6300 & 6302)	white, brown, gold, black
4030			10 mm 0,39"	1,5 kg 3,3 lbs	4100, 4200, 4520, 4530, 4540, 4550, 4800, 5100, 5600, 6200 (also 6300 & 6302)	white, brown, gold
6009			10 mm 0,39"	2 kg 4,4 lbs	all wide channel profiles	white
6010			15 mm 0,59"	0,5 kg 1,1 lbs	4200, 5100, 5600, 6200	white
6529-12			10 mm 0,39"	0,5 kg 1,1 lbs	6200 (as in 6500, 6600 & 6602)	white
6710			20 mm 0,79"	3 kg 6,6 lbs	6200 (as in 6700)	white